

Product Datasheet

ECO-Y 1000-4-HE-C-XXb

1000kg D8 Electric Chain Hoist with Direct Control

1000 kg

D8

4 m/min

Fixed

Rugged

EN14492



Moveket GmbH
Rudolf-Diesel-Straße 21
71154 Nufringen, Germany



Web: www.moveket.de
E-Mail: support@moveket.de
Phone: +49 7032 371170

Overview

Table of Contents

1. General Description	3
2. Technical Data	4
2.1 Specifications	4
2.2 Equipment	4
2.3 Electrical Data	4
2.4 Mechanical Data	4
2.5 Operating Conditions	4
3. Dimension Sheet	5
4. Connection Assignments	6

Figure Directory

Fig. 1	Overview drawing	4
Fig. 2	Dimension Sheet	5
Fig. 3	Connection Assignments	6
Fig. 4	Brake Circuitry	6

Revision Management

1.0	19.11.2024	DS	N. Braun	Initial Creation
-----	------------	----	----------	------------------



General Description

Model Designation

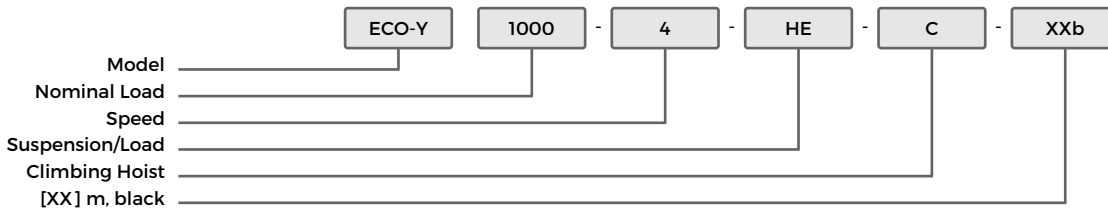

Moveket is a leading manufacturer of electric chain hoists, control systems, and safety technology. Our products stand for the highest level of safety, compact design, and "Made in Germany" quality. With over 35 years of experience in stage technology, we offer innovative solutions suitable for both permanent installations and touring operations.

Functionality

Our electric chain hoists are based on a modular design principle and can be flexibly configured. For example, load cells, incremental encoders, or gear limit switches can be easily retrofitted. Moveket's product range covers all applications for Use Cases 1 to 6 in accordance with EN 17206 and offers tailored solutions in various configurations, including D8 and D8+ setups. Moveket places the highest emphasis on precision and reliability to meet the demands of modern stage operations.

Application

Moveket's electric chain hoists are suitable for both stationary installations and mobile use in touring productions. They are ideal for stage and event technology, providing a safe and efficient solution for demanding projects worldwide.

Additional Features

Our products combine safety, durability, and ease of use. The compact dimensions and versatile configuration options ensure optimal adaptation to any requirement. Thanks to their modular design, subsequent adjustments can be easily implemented.

Box-Building Principle

The Moveket Box-Building Principle allows us to customize and flexibly expand our products. Various components such as load measurement systems, additional safety features, or specialized control modules can be integrated at any time to meet the demands of an ever-changing market. Do you have any questions or need further information? Feel free to contact your Moveket dealer, distributor, or reach out to us directly as the manufacturer.

2006/42/EG Machinery	2014/35/EU Low Voltage	2014/30/EU EMI	2011/65/EU RoHS	12100 DIN EN ISO	62061 DIN EN IEC	61000 DIN EN IEC
-------------------------	---------------------------	-------------------	--------------------	---------------------	---------------------	---------------------

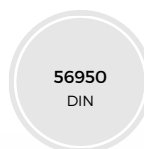

Technical Data

Technical Specifications

Model	ECO-Y 1000-4
Type	SK070/16U
Motor	K20R 80K4E
Maximum Load	1000 kg
Safety	5 static
Load Strands	1
Brake Type	DC double brake
Lifting Speed 50Hz	4 m/min
Lifting Height	to 0 m
Chain Type	7x22
Gear Group	2m/M5
Usage Duration	1600 h
Noise Level	74 dB(A)

Electrical Data

Operating Voltage	380 V AC - 420 V AC
Control Type	Direct Control
Control voltage	Unbekannt
Frequency	50 Hz
Power Factor cos(phi)	0.8
Electrical Nominal Power	1.39 kW
Current Consumption	4.36 A

Mechanical Data

Mechanical Nomin. Power	1.1 kW
Dimensions [L,W,H]	Nicht verfügbar
Weight Without Chain	37 kg
Chain Weight	1.10 kg/m
Nominal Speed	1410 1/min

Operating Conditions

Duty Cycle at +40°C	40 %
Max. Switching Cycles /h	240
Temperature Range	-20°C to +40°C
Protection Type (IP)	55

Overview drawing

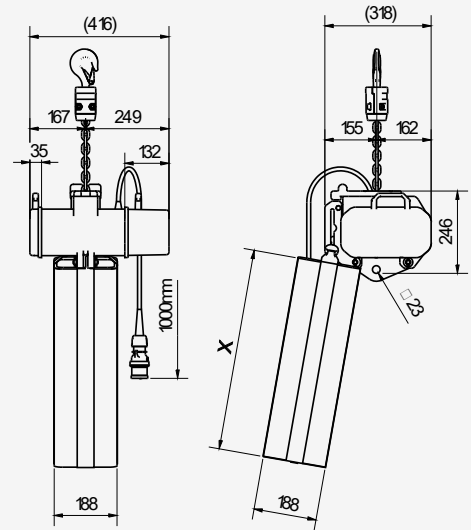

Model Variant: []

Suspension	Load Hook
Load Handling	Single Hole Eyelet
Chain Introduction	Chain Introduction (Easyplate)
Chain Storage	Textile

Equipment: Direct Control

Gear Limit Switch	No, opt.
Dynamic Load Measuring Device	No, opt.
Incremental Encoder	No, opt.
Absolute Encoder	No, opt.



Technical Dimensions

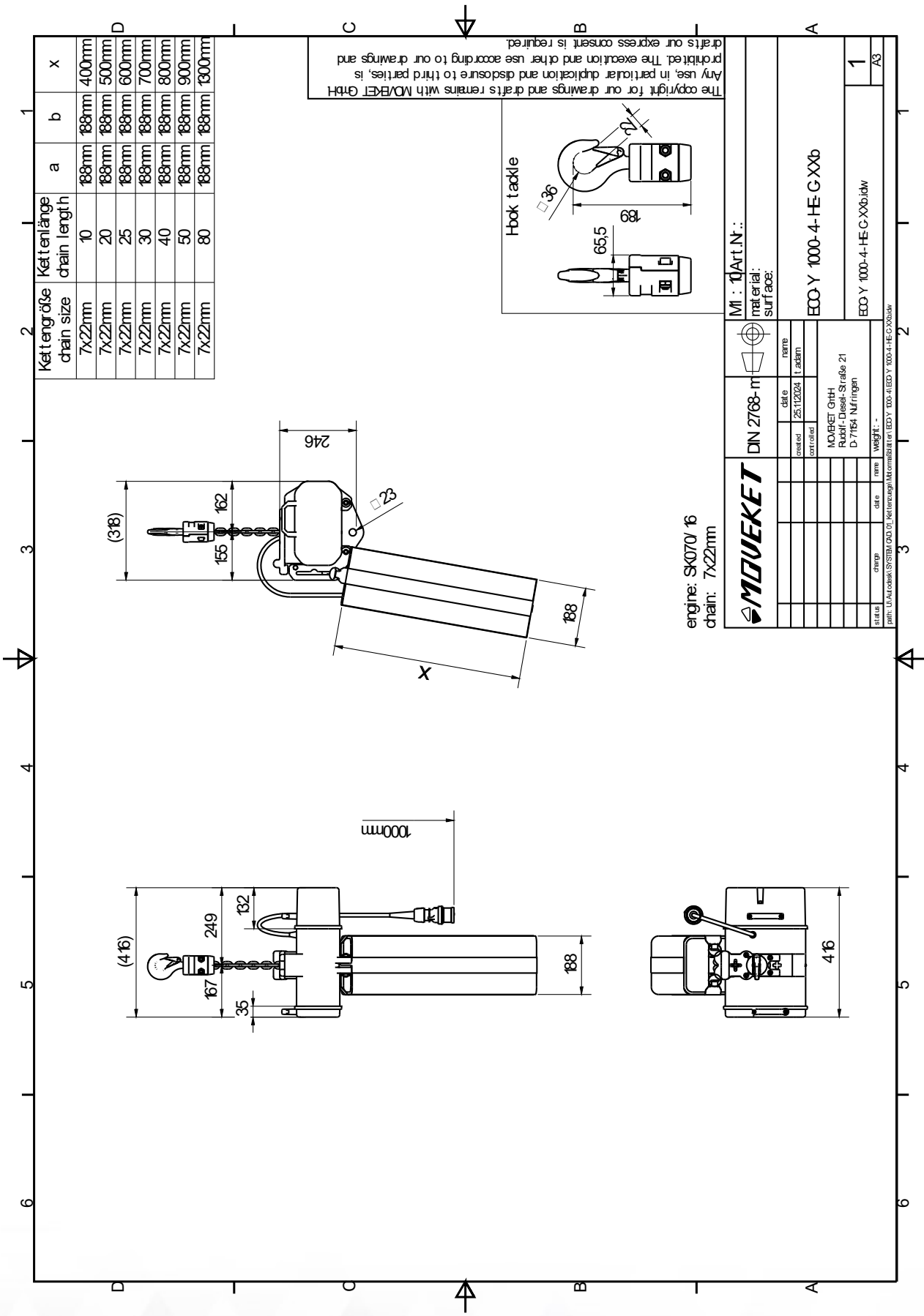

The copyright for our drawings and drafts remains with MOVEKET GmbH. Any use, in particular duplication and disclosure to third parties, is prohibited. The execution and other use according to our drawings and drafts is our express consent is required.

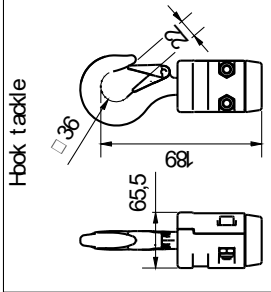

engine: SK070/16
chain: 7x22mm



Connection Assignments

CEE 4PoI Motor Power

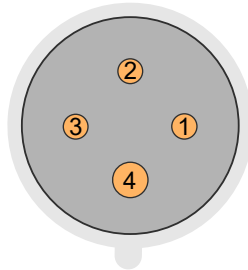

Pin	Descr.	Funct.	Wire
1	L1	U	1.5 mm ²
2	L2	V	1.5 mm ²
3	L3	W	1.5 mm ²
4	PE	PE	1.5 mm ²



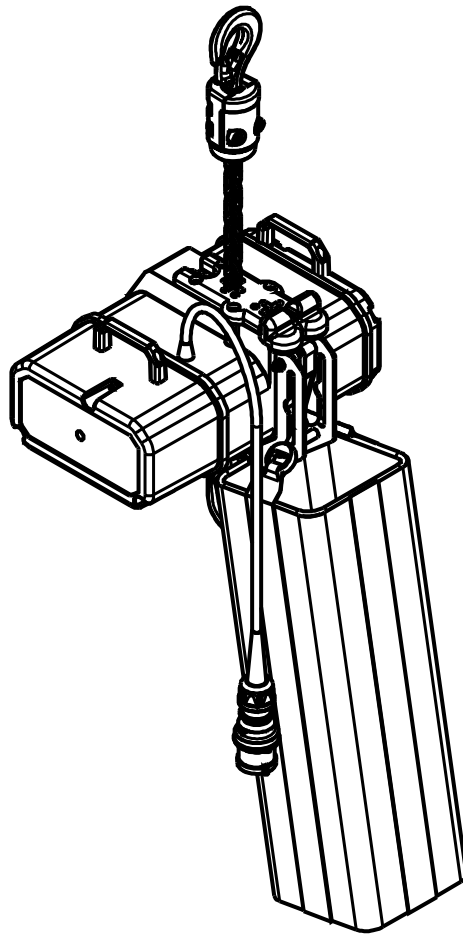

Product Datasheet

ECO-Y 1000-4-HH-C-XXb

1000kg D8 Electric Chain Hoist with Direct Control

1000 kg

D8

4 m/min

Fixed

Rugged

EN14492



Moveket GmbH
Rudolf-Diesel-Straße 21
71154 Nufringen, Germany



Web: www.moveket.de
E-Mail: support@moveket.de
Phone: +49 7032 371170

Overview

Table of Contents

1. General Description	3
2. Technical Data	4
2.1 Specifications	4
2.2 Equipment	4
2.3 Electrical Data	4
2.4 Mechanical Data	4
2.5 Operating Conditions	4
3. Dimension Sheet	5
4. Connection Assignments	6

Figure Directory

Fig. 1	Overview drawing	4
Fig. 2	Dimension Sheet	5
Fig. 3	Connection Assignments	6
Fig. 4	Brake Circuitry	6

Revision Management

1.0	19.11.2024	DS	N. Braun	Initial Creation
-----	------------	----	----------	------------------



General Description

Model Designation

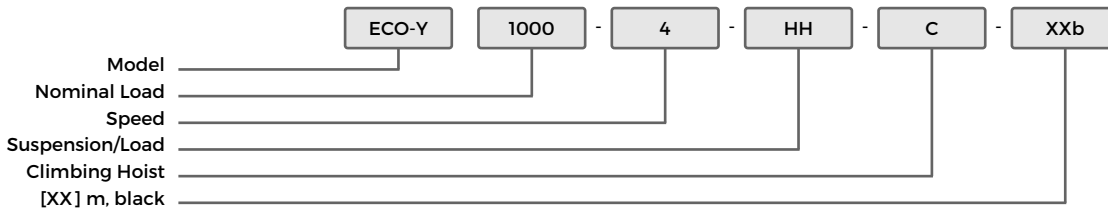

Moveket is a leading manufacturer of electric chain hoists, control systems, and safety technology. Our products stand for the highest level of safety, compact design, and "Made in Germany" quality. With over 35 years of experience in stage technology, we offer innovative solutions suitable for both permanent installations and touring operations.

Functionality

Our electric chain hoists are based on a modular design principle and can be flexibly configured. For example, load cells, incremental encoders, or gear limit switches can be easily retrofitted. Moveket's product range covers all applications for Use Cases 1 to 6 in accordance with EN 17206 and offers tailored solutions in various configurations, including D8 and D8+ setups. Moveket places the highest emphasis on precision and reliability to meet the demands of modern stage operations.

Application

Moveket's electric chain hoists are suitable for both stationary installations and mobile use in touring productions. They are ideal for stage and event technology, providing a safe and efficient solution for demanding projects worldwide.

Additional Features

Our products combine safety, durability, and ease of use. The compact dimensions and versatile configuration options ensure optimal adaptation to any requirement. Thanks to their modular design, subsequent adjustments can be easily implemented.

Box-Building Principle

The Moveket Box-Building Principle allows us to customize and flexibly expand our products. Various components such as load measurement systems, additional safety features, or specialized control modules can be integrated at any time to meet the demands of an ever-changing market. Do you have any questions or need further information? Feel free to contact your Moveket dealer, distributor, or reach out to us directly as the manufacturer.

2006/42/EG Machinery	2014/35/EU Low Voltage	2014/30/EU EMI	2011/65/EU RoHS	12100 DIN EN ISO	62061 DIN EN IEC	61000 DIN EN IEC
-------------------------	---------------------------	-------------------	--------------------	---------------------	---------------------	---------------------

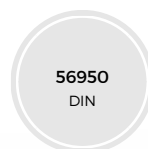

Technical Data

Technical Specifications

Model	ECO-Y 1000-4
Type	SK070/16U
Motor	K20R 80K4E
Maximum Load	1000 kg
Safety	5 static
Load Strands	1
Brake Type	DC double brake
Lifting Speed 50Hz	4 m/min
Lifting Height	to 0 m
Chain Type	7x22
Gear Group	2m/M5
Usage Duration	1600 h
Noise Level	74 dB(A)

Electrical Data

Operating Voltage	380 V AC - 420 V AC
Control Type	Direct Control
Control voltage	Unbekannt
Frequency	50 Hz
Power Factor cos(phi)	0.8
Electrical Nominal Power	1.39 kW
Current Consumption	4.36 A

Mechanical Data

Mechanical Nomin. Power	1.1 kW
Dimensions [L,W,H]	Unbekannt
Weight Without Chain	37 kg
Chain Weight	1.10 kg/m
Nominal Speed	1410 1/min

Operating Conditions

Duty Cycle at +40°C	40 %
Max. Switching Cycles /h	240
Temperature Range	-20°C to +40°C
Protection Type (IP)	55

Overview drawing

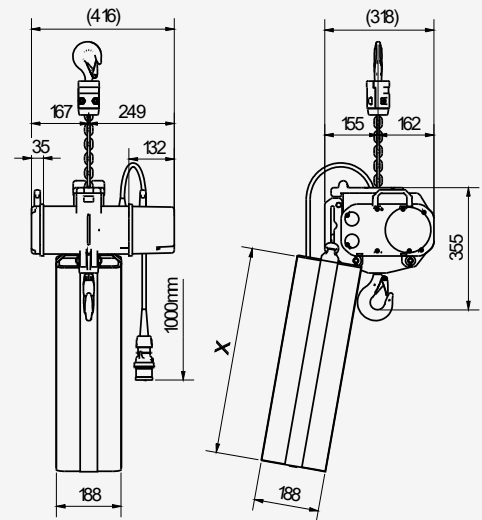

Model Variant: []

Suspension	Load Hook
Load Handling	[]
Chain Introduction	Chain Introduction (Easyplate)
Chain Storage	Textile

Equipment: Direct Control

Gear Limit Switch	No, opt.
Dynamic Load Measuring Device	No, opt.
Incremental Encoder	No, opt.
Absolute Encoder	No, opt.



Technical Dimensions

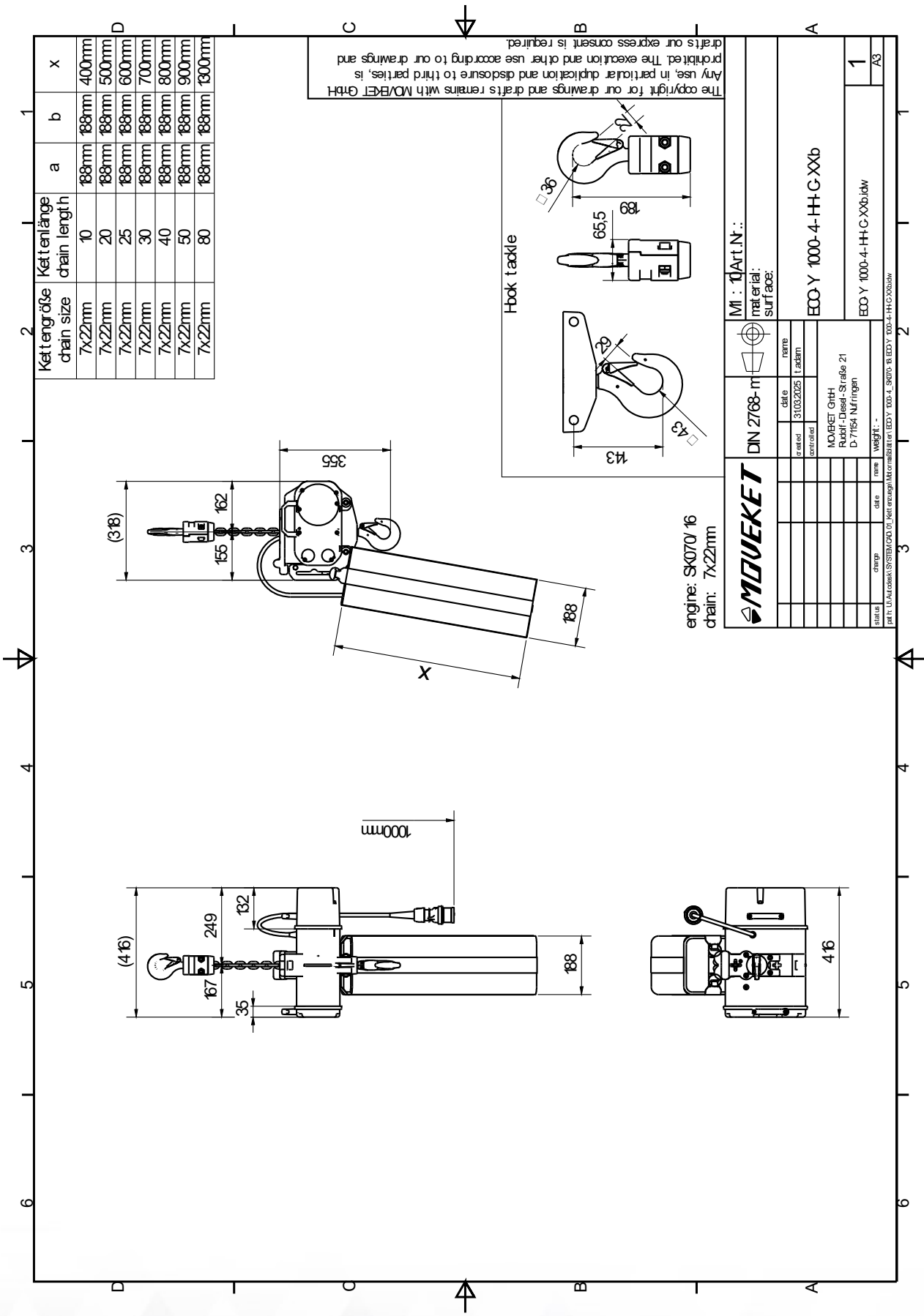

The copyright for our drawings and drafts remains with MOVEKET GmbH. Any use, in particular duplication and disclosure to third parties, is prohibited. The execution and other use according to our drawings and drafts is our express consent is required.

MOVEKET		name		Mi : 10 Art N.:	
DN 2768-m	date	31.03.2025	Ladlam	material:	ECO Y 1000-4-HH-C-XXb
created	controlled			surface:	ECO Y 1000-4-HH-C-XXb.idw
					1
					A3
status	change	date	name	weight	
PKT_U\A\Globe\SYSTEM\COO_01_Kett_1000-4-HH-C-XXb.dwg			MOVEKET GmbH Rudolf-Diesel-Str. 21 D-71534 Nürtingen		



Connection Assignments

CEE 4PoI Motor Power

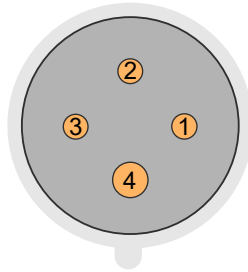

Pin	Descr.	Funct.	Wire
1	L1	U	1.5 mm ²
2	L2	V	1.5 mm ²
3	L3	W	1.5 mm ²
4	PE	PE	1.5 mm ²

